

Nephelometric system, approved alternative method to US EPA 180.1, for the automatic and continuous measurement of turbidity in potable water, surface water and effluent.

Monitor AMI Turbiwell W/LED

- Non-contact turbidimeter: System optics are not in direct contact with sample, no fouling on optical surfaces.
- Measuring range: 0.000 - 100.0 NTU
Automatic range switching.
- Precision: ± 0.003 NTU or ± 1% of reading.
- Complete system including transmitter, control electronics, sample chamber and turbidimeter.
- Manual or automatic valve for the drain of the sample chamber.
- Easy user menus in English, German, French and Spanish. Simple programming of all parameters by keypad.
- Electronic record of major process events and calibration data.
- Real-time clock for time stamp in data logs and for automated functions.
- Data logger for 1'500 data records stored at selectable intervals. (Data download to PC requires optional HyperTerminal interface).
- Big back-lit LCD display for the reading of all measured values and status information simultaneously.
- Measurement values are available as analog output signals.
- Potential-free alarm contact as summary alarm indication for programmable alarm values and for instrument errors.
- Input for potential-free contact to freeze the measuring value or to interrupt control in automated installations (hold function or remote-off).
- Factory tested, ready for installation and operation.

Accessories:

- Turbidity verification kits (dry verification)

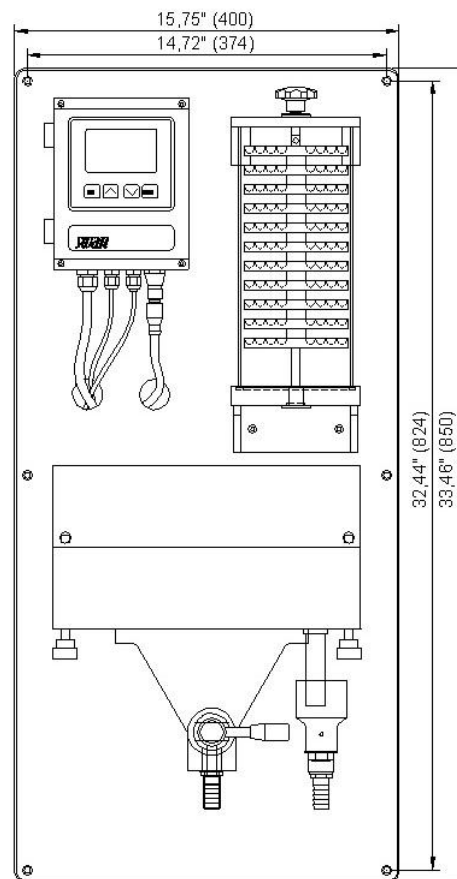

Monitor AMI Turbiwell W/LED with manual drain valve and optional sample degasser.

Optional:

- Communication *interfaces*
- *Sample degasser* to avoid the formation of interfering bubbles in the samples
- *SS deltaT* flow meter

Order scheme	Monitor AMI Turbiwell W/LED	A	2	5	4	1	X	7	X	X	X
Power supply	100 - 240 VAC, 50/60 Hz						1				
	24 VDC, direct current						2				
Signal output option	None								0		
	Profibus DP interface								2		
	HyperTerminal interface (for logger download)								3		
	Modbus interface (for <i>Webserver</i> connection)								4		
Sample degasser option	None									0	
	Sample degasser									1	
Drain valve	Manual drain valve										1
	Automatic drain valve: "Auto-Drain" with electrical motor										2

Turbidimeter System

Nephelometer using a white light LED light source. Approved alternative method to US EPA 180.1.
Method number: SWAN AMI Turbiwell

Measuring range: 0.000 to 100.0 NTU
Precision: ± 0.003 NTU or $\pm 1\%$, whichever is greater

Two-part turbidimeter body made of PETP with drain valve.
Heated optics, windows and sample compartment to avoid condensation.

Easy cleaning of sample compartment.

Factory calibrated with Formazine.

Optional sample flow measurement with SWAN deltaT flow sensor.

Transmitter Specifications and Functionality

Electronics case: Aluminum
Protection degree: IP 66 / NEMA 4X
Display: backlit LCD, 2,95 x 1,77"
Electrical connectors: screw clamps
Ambient temperature: 14 to 122 °F
Limit range of operation: -13 to 149 °F
Storage and transport: -22 to 185 °F
Humidity: 10 to 90 % relative, non condensing

Power supply

Voltage: 100 - 240 VAC ($\pm 10\%$),
50/60 Hz ($\pm 5\%$)
or 24 VDC ($\pm 15\%$)
Power consumption: max. 20 VA

Operation

Easy operation based on separate menus for "Messages", "Diagnostics", "Maintenance", "Operation" and "Installation".

Separate, menu specific password protection.

Display of process value, alarm status and time during operation.

Storage of event log, alarm log and calibration history.

Storage of the last 1'500 data records in logger with selectable time interval.

Real-time clock with calendar

For action time stamp and preprogrammed actions.

Safety features

No data loss after power failure, all data are saved in non-volatile memory.
Over-voltage protection of in- and outputs.
Galvanic separation of measuring inputs and signal outputs.

Transmitter temperature monitoring

With programmable high/low alarm limits.

Electrical Connection Scheme

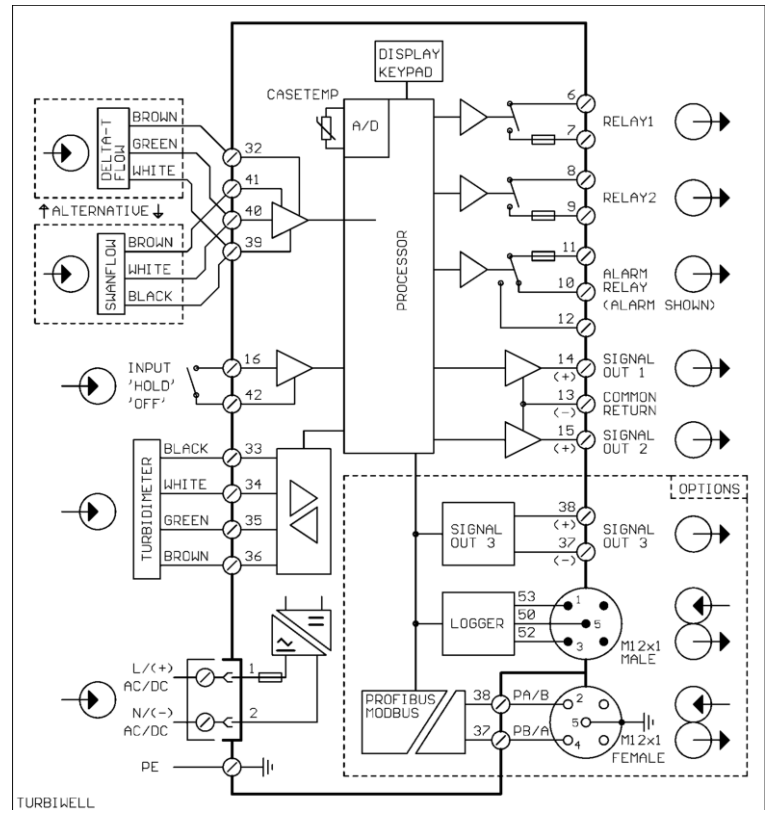

1 Alarm relay

One potential free contact for summary alarm indication for programmable alarm values and instrument errors.
Maximum load: 1A / 250 VAC

1 Input

One input for potential-free contact.
Programmable hold or remote off function.

2 Relay outputs

Two potential-free contacts programmable as limit switches for measuring values, controllers or timer with automatic hold function.
Rated load: 1A / 250 VAC

2 Signal outputs

Two programmable signal outputs for measured values (freely scaleable, linear or bilinear) or as continuous control outputs (control parameters programmable).
Current loop: 0/4 - 20 mA
Maximum burden: 510 Ω

Control functions

Relays or current outputs programmable for 1 or 2 pulse dosing pumps, solenoid valves or for one motor valve.
Programmable P, PI, PID or PD control parameters.

1 Communication interface (option)

RS232 interface for logger download to PC with Microsoft HyperTerminal or RS485 interface (galvanically separated) with Fieldbus protocol Modbus or Profibus DP.

Remote instrument access with PC requires Modbus interface and optional *Webserver*.

Sample and Monitor Data

Sample conditions

Flow rate: approx. 5 – 16 gal/h
Temperature: up to 104 °F
Sample temperature max. 9°F over ambient temperature
Outlet pressure: pressure free, atmospheric drain

Sample connections

Inlet: 1/4" thread / nozzle, \varnothing 0,39" (10mm)
Drain: 1/2" thread / \varnothing 0,62" (16 mm), tubing 0,59 x 0,78" (15 x 20 mm)

Panel

Dimensions: 15,75 x 33,46 x 7,87"
(400 x 850 x 200mm)
Material: white PVC
Weight: 22.0 lbs